

Unit – 4 (ISOMETRIC PROJECTION)

When a solid is resting in its simple position, the front or top view, taken separately, gives an incomplete idea of the form of the object. When the solid is tilted from its simple position such that its axis is inclined to both H.P and V.P, the front view or the top view or sometimes both, give an „air idea of the pictorial form of the object, i.e., all the surfaces are visualized in a single orthographic view.

“Iso” means „equal“ and “metric projection” means „a projection to a reduced measure“. An isometric projection is one type of pictorial projection in which the three dimensions of a solid are not only shown in one view, but also their dimension can be scaled from this drawing.

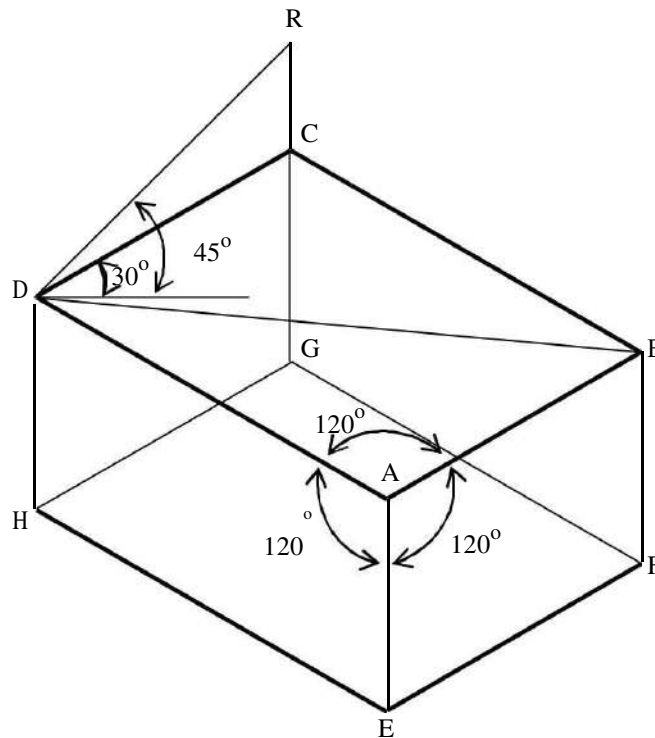

It is seen that all the edges and faces of the rectangular prism are equally inclined to the plane of all the edges and faces of the cube are equally inclined to the plane of projection. Hence the rectangular faces are seen as similar and equal rhombuses.

The three lines AB, AD and AE are meeting at A. These edges are mutually perpendicular to each other in the solid. Since all these edges are equally inclined to H.P, they are making an angle of 120° with each other in the plane of projection; also they are equally foreshortened. This leads us to the problem of selecting an isometric scale.

Isometric Axes:

The lines AB, AD and AE meeting at a point A and making an angle of 120° with each other are termed „isometric axes“

Isometric Lines:

The lines parallel to the isometric axes are termed isometric lines. The lines CD, CB etc are examples of isometric lines.

Non-isometric Lines:

The lines which are not parallel to isometric axes are termed non-isometric lines. The BD is an example.

Isometric Planes:

The planes representing the faces of the rectangular prism as well as other planes parallel to these planes are termed isometric planes.

Isometric scale:

Isometric projection is drawn using isometric scale, which converts true lengths into isometric lengths (foreshortened)

Construction of isometric scale:

- Draw a horizontal line AB.
- From A draw a line AC at 45° to represent actual or true length and another line AD at 30° to AB to measure isometric length.
- On AC mark the point 0, 1, 2 etc to represent actual lengths.
- From these points draw verticals to meet AD at 0', 1', 2' etc. The length A1' represents the isometric scale length of A1 and so on.

C

Isometric Length

3

$$\frac{AB}{AC} = \cos 45^\circ = \frac{1}{\sqrt{2}}$$

$$\frac{AB}{AD} = \cos 30^\circ = \frac{\sqrt{3}}{2}$$

$$\therefore \frac{AB}{AC} \div \frac{AB}{AD} = \frac{1}{\sqrt{2}} \div \frac{\sqrt{3}}{2}$$

$$\frac{AB}{AC} \times \frac{AD}{AB} = \frac{2}{\sqrt{2}} \times \frac{2}{\sqrt{3}}$$

$$\frac{AD}{AC} = \frac{\sqrt{2}}{\sqrt{3}} = 0.81$$

$$\Rightarrow AD = 0.81 \times AC$$

$$\therefore \text{Isometric Length} = 0.81 \times \text{Actual Length}$$

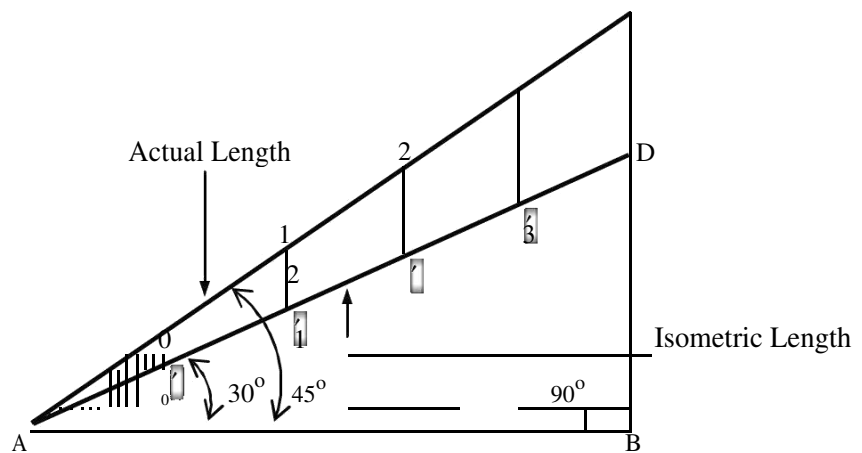

Difference between isometric view and isometric projection

Isometric View	Isometric Projection
Drawn to actual scale	Drawn to isometric scale
When lines are drawn parallel to isometric axes, the true lengths are laid off.	When lines are drawn parallel to isometric axes, the lengths are foreshortened to 0.81 time the actual lengths.

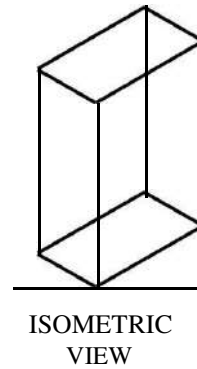
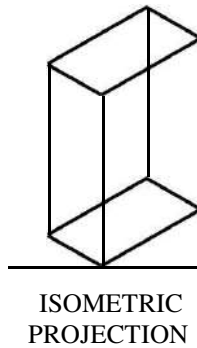
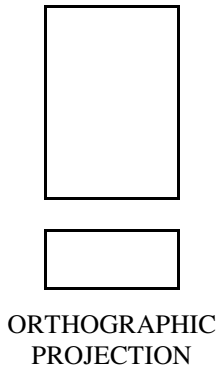

Isometric Plane and Non-isometric Plane:

Isometric Planes are marked as 1 and Non-isometric Planes are marked as 2

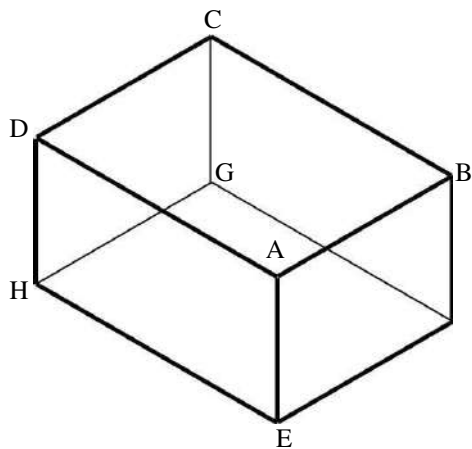
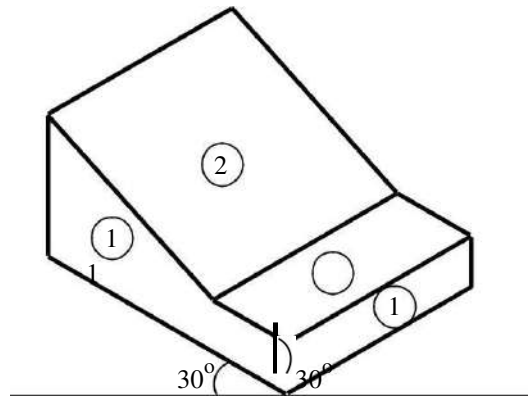

F

Problem

Draw the isometric projection of a rectangular prism of base 50 mm × 10 mm and height 75 mm, when it rests with its base on H.P and one its of rectangular faces is parallel to V.P

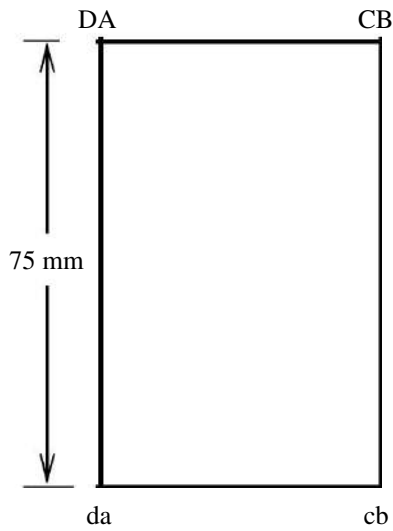

FRONT VIEW

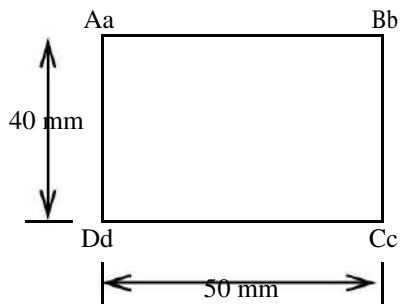

TOP VIEW

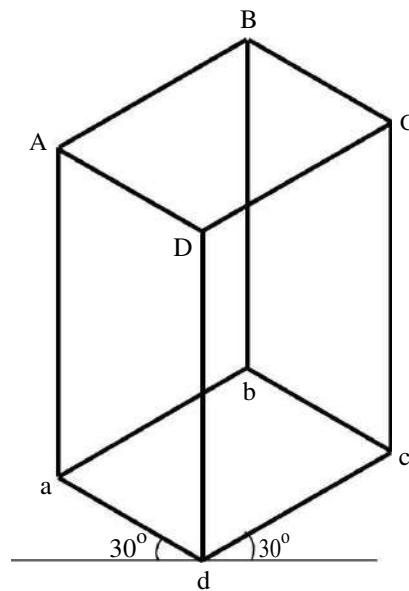
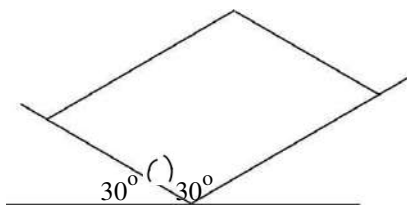
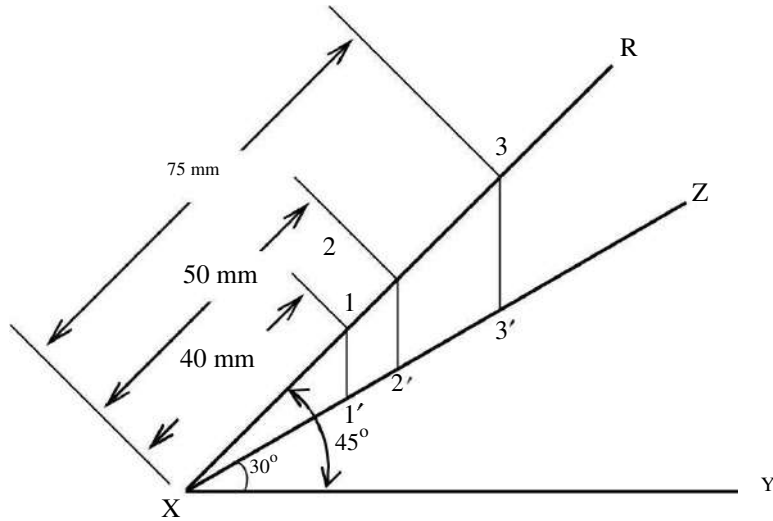

BOX METHOD:

The isometric projection of solids like cube, square and rectangular prisms are drawn directly when their edges are parallel to the three isometric axes. The isometric projection of all other types of prisms and cylinders are drawn by enclosing them in a rectangular box. This method is called **Box method**.

EXAMPLE – 1

Draw an isometric of a Pentagonal prism of base 1.5" and length 2.5" resting on one of its rectangular faces on H.P

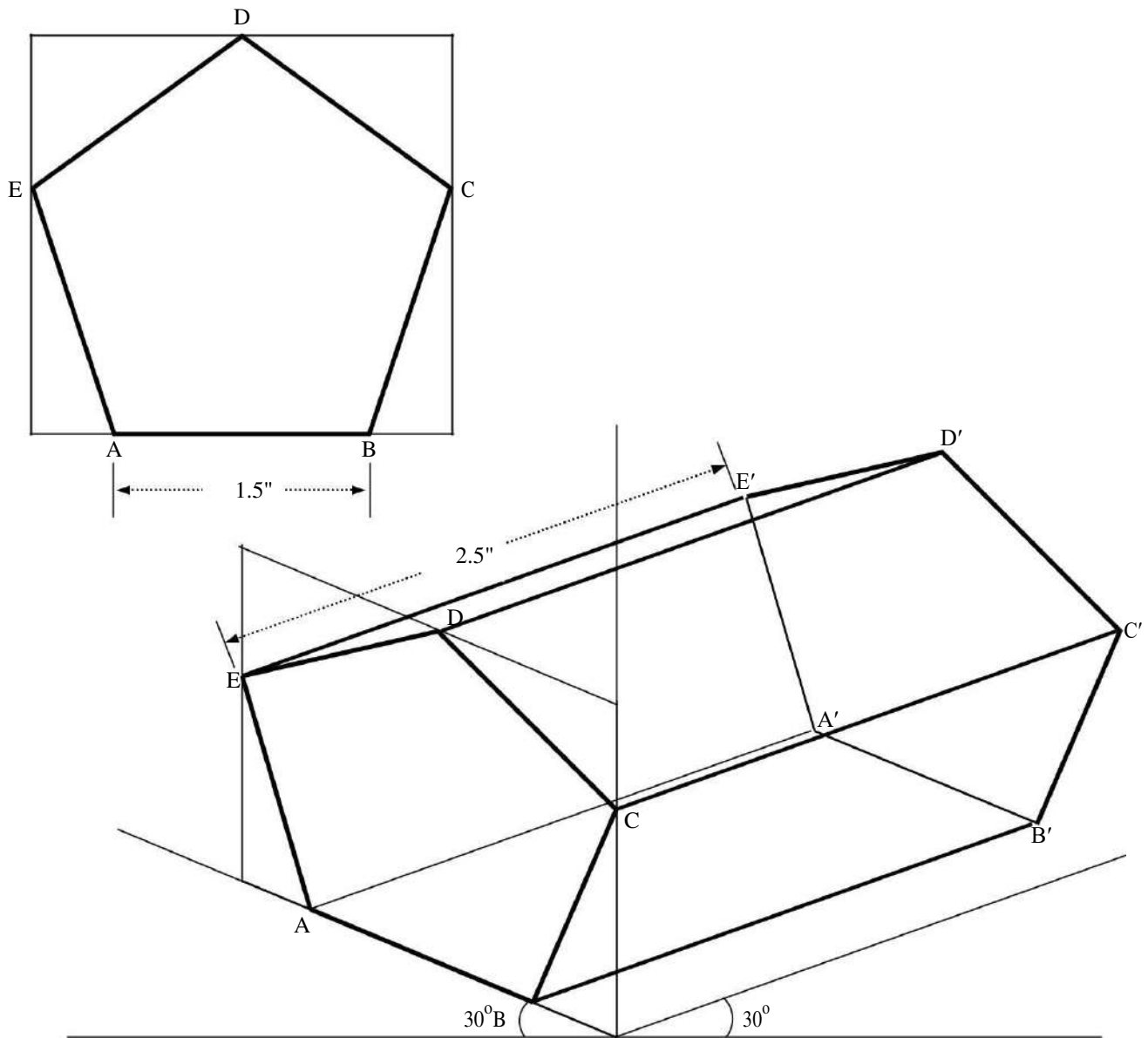

**ISOMETRIC VIEW OF A REGULAR PENTAGONAL PRISM
(Resting on one of its rectangular faces on H.P)**

EXAMPLE – 2

Draw an isometric of a Hexagonal Prism of base 1" and length 3" resting on one of its rectangular faces on H.P

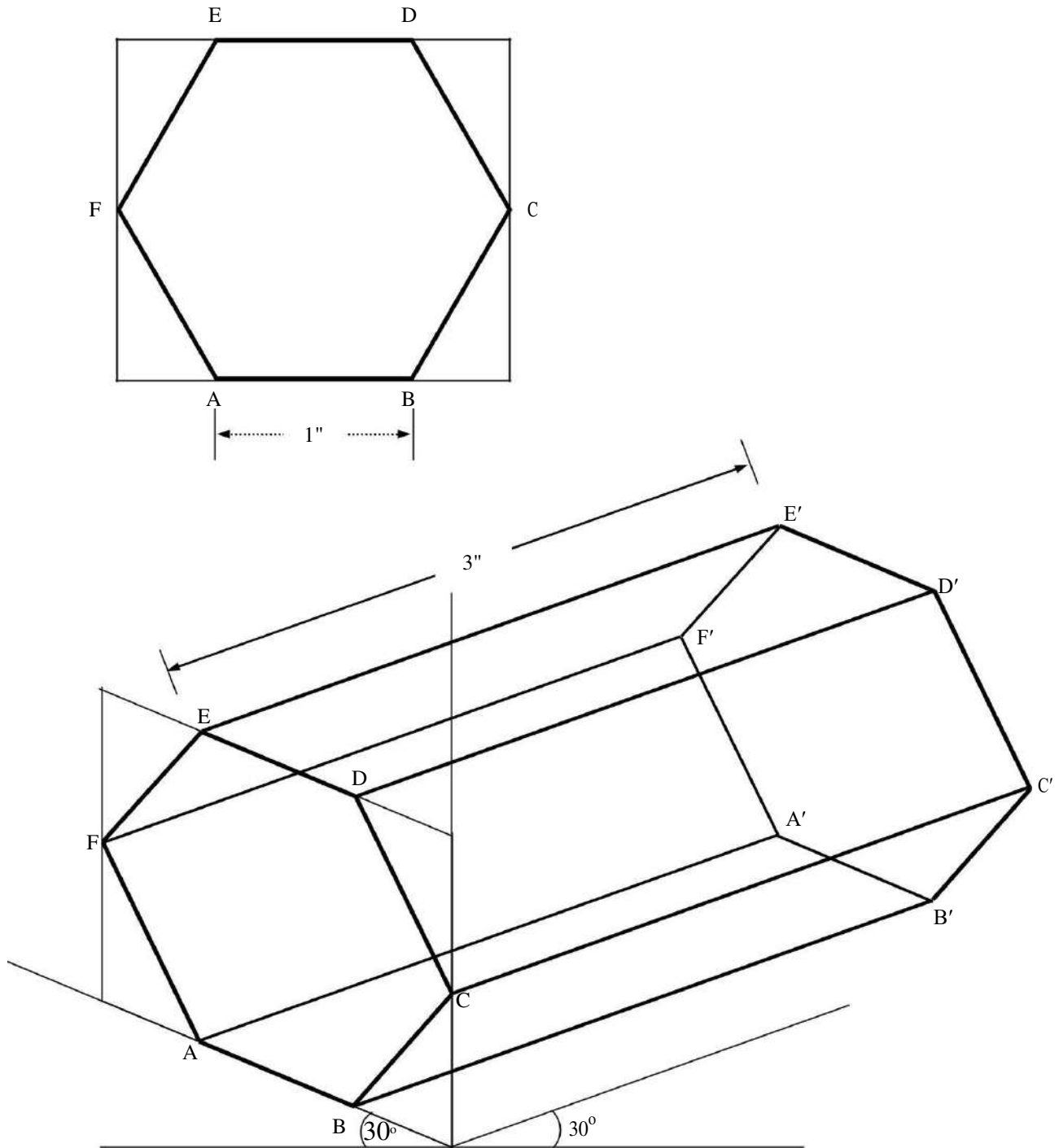

**ISOMETRIC VIEW OF A REGULAR HEXAGONAL PRISM
(Resting on one of its rectangular faces on H.P)**

EXAMPLE – 3

Draw an isometric of a Octagonal Prism of base 1.5" and length 2.5" resting on one of its rectangular faces on H.P

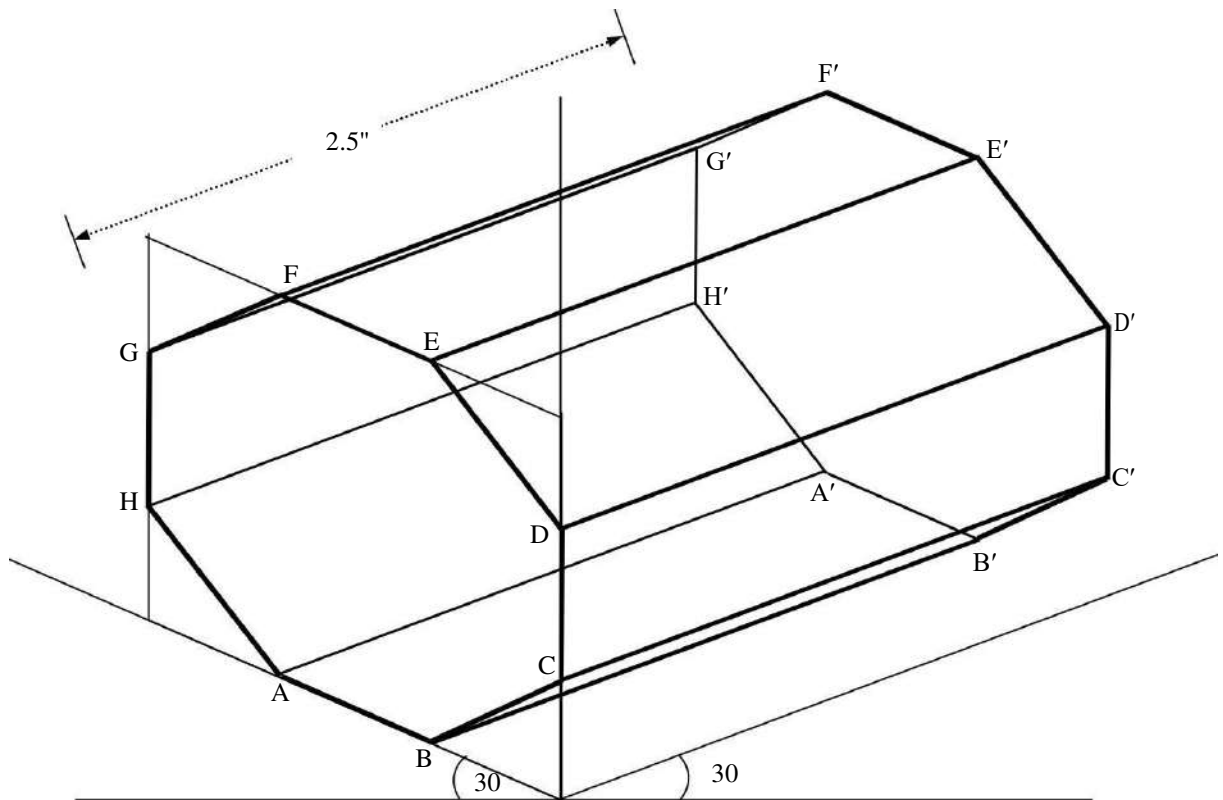
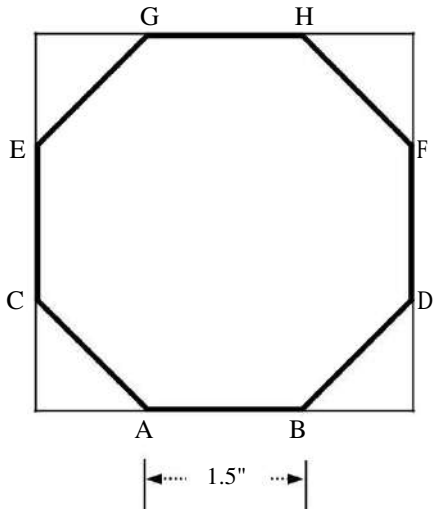

**ISOMETRIC VIEW OF AN OCTAGONAL PRISM
(Resting on one of its rectangular faces on H.P)**

EXAMPLE – 4

Draw an isometric of a regular Hexagonal Pyramid of base 1" and height 3" resting on one of its hexagonal faces on H.P

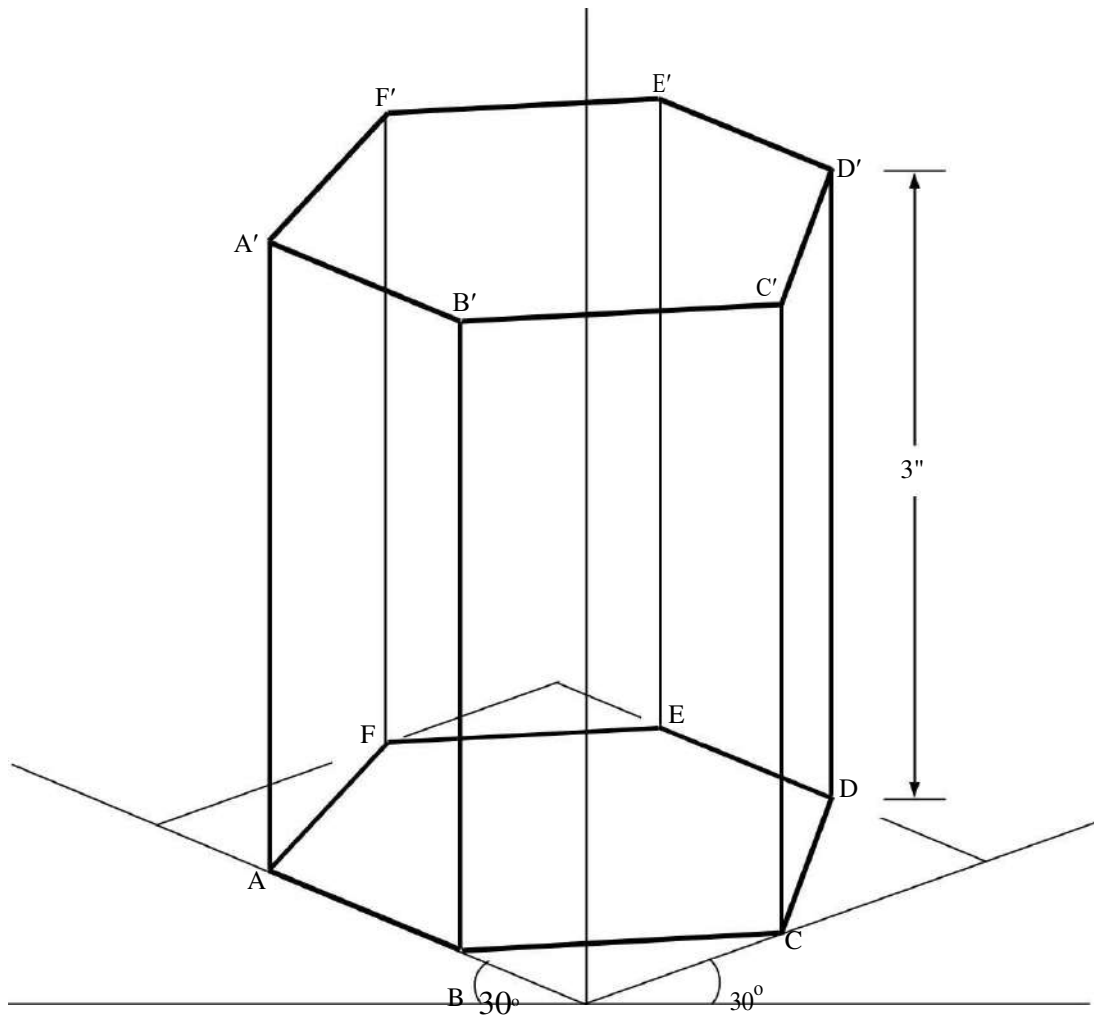
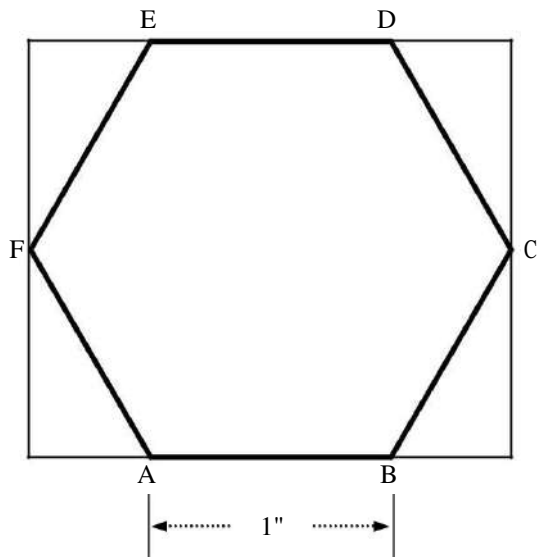

**ISOMETRIC VIEW OF A REGULAR HEXAGONAL PRISM
(Resting on one of its hexagonal faces on H.P)**

FOUR CENTERED METHOD:

EXAMPLE – 5

Draw an isometric of a cylinder of base 1" diameter and height 3" lying on H.P

Drawing Procedure

- Join P with B and C which are the mid-points of the opposite sides of the rhombus. Similarly join R with A and D.
- With P as centre and PC as radius draw an arc CB. Similarly with R as centre and RA as radius draw an arc AD.
- The lines PC and RD intersect at O_1 . With O_1 as centre and O_1D as radius draw an arc DC.
- Similarly with O_2 (intersection of RA and PB) as centre and O_2B as radius draw an arc BA. Thus complete the ellipse.
- Refer step 1-3 in the Offset method and complete the isometric view of the cylinder.

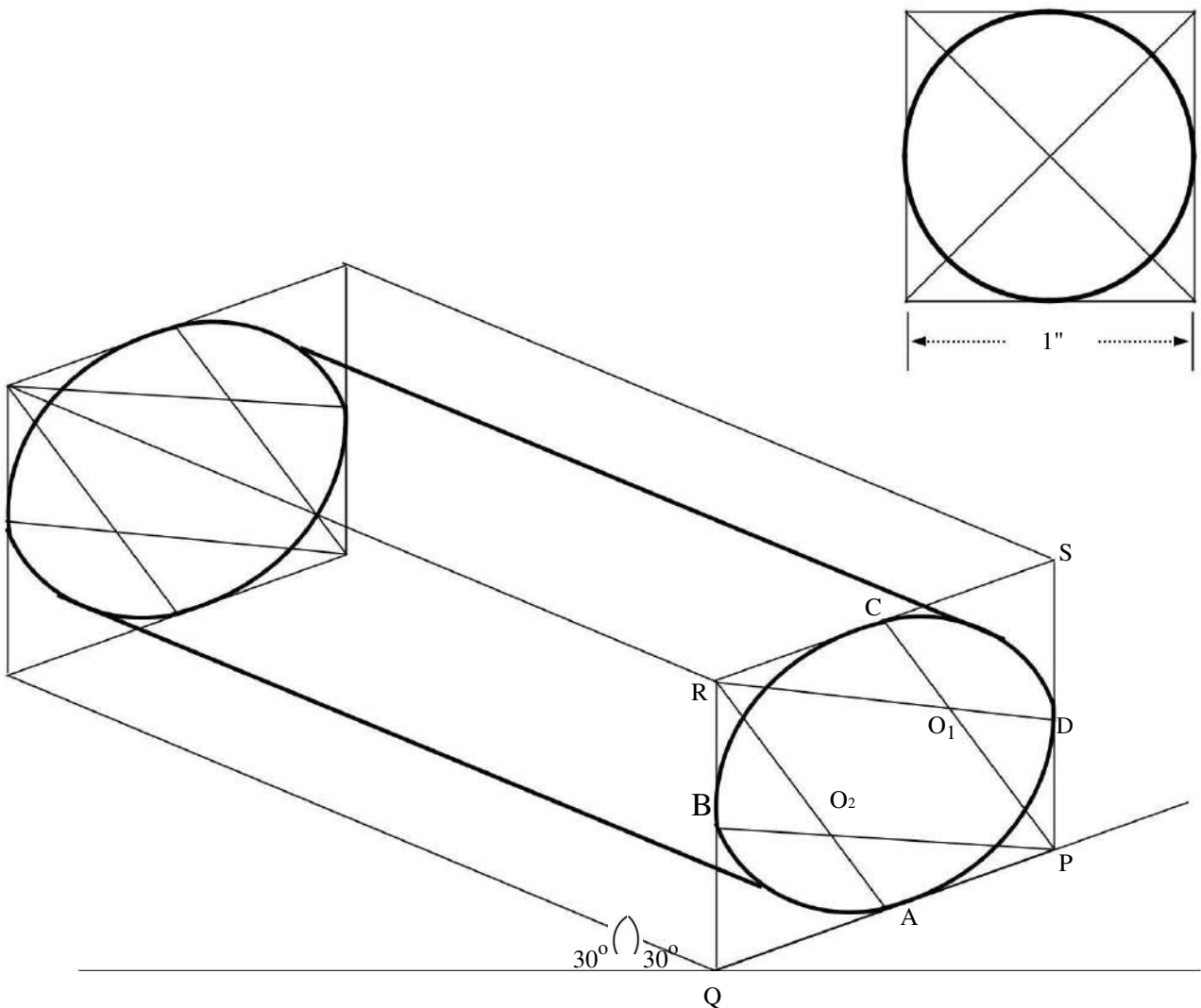

**ISOMETRIC VIEW OF A CYLINDER
(Lying on H.P)**

EXAMPLE – 6

Draw an isometric of a cylinder of base 1" diameter and height 3" lying on V.P

Drawing Procedure

- Join P with B and C which are the mid-points of the opposite sides of the rhombus. Similarly join R with A and D.
- With P as centre and PC as radius draw an arc CB. Similarly with R as centre and RA as radius draw an arc AD.
- The lines PC and RD intersect at O_1 . With O_1 as centre and O_1D as radius draw an arc DC.
- Similarly with O_2 (intersection of RA and PB) as centre and O_2B as radius draw an arc BA. Thus complete the ellipse.
- Refer step 1-3 in the Offset method and complete the isometric view of the cylinder.

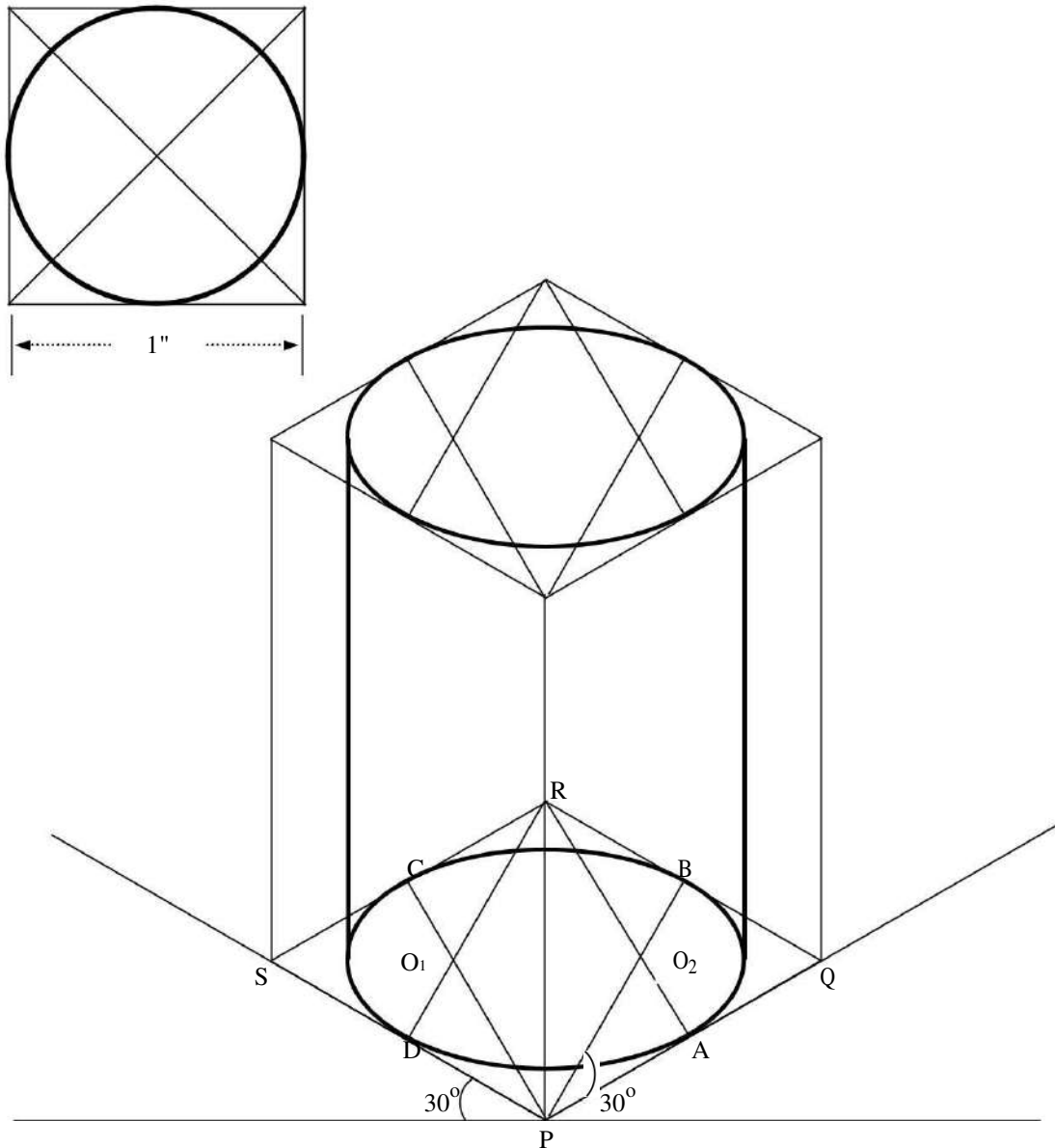

**ISOMETRIC VIEW OF A CYLINDER
(Lying on V.P)**

CO-ORDINATE OR OFFSET METHOD:

EXAMPLE – 1

The isometric view of a hexagonal pyramid of side of base 30 mm and height 75 mm, when it is resting on H.P such that an edge of the base is parallel to V.P

Drawing Procedure

- Draw the top and front views of the hexagonal pyramid.
- Enclose the hexagon in a rectangle $PQRS$ in the top view.
- Draw the isometric vies of the base of the pyramid in the parallogram $PQRS$.
- Note that FC is an isometric line on which O_1 lies. Hence mark O_1 on the isometric line FC such that $FO_1 = y$.
- From O_1 erect a vertical line and mark the apex O such that $O_1O = \text{length of the axis} = 75 \text{ mm}$
- Join O with all the corners of the base of the pyramid and complete the isometric as shown.

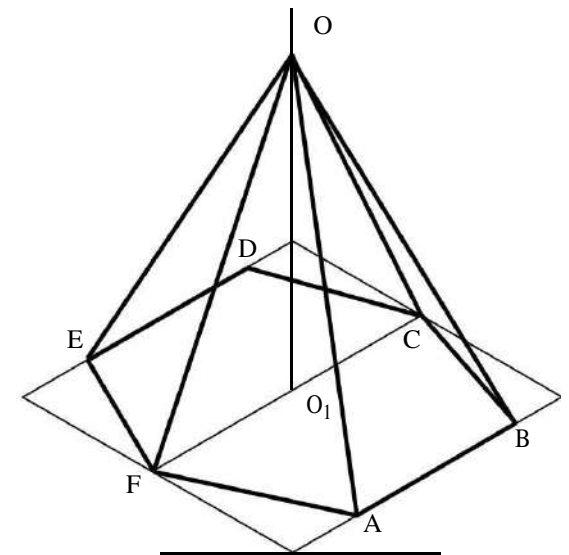
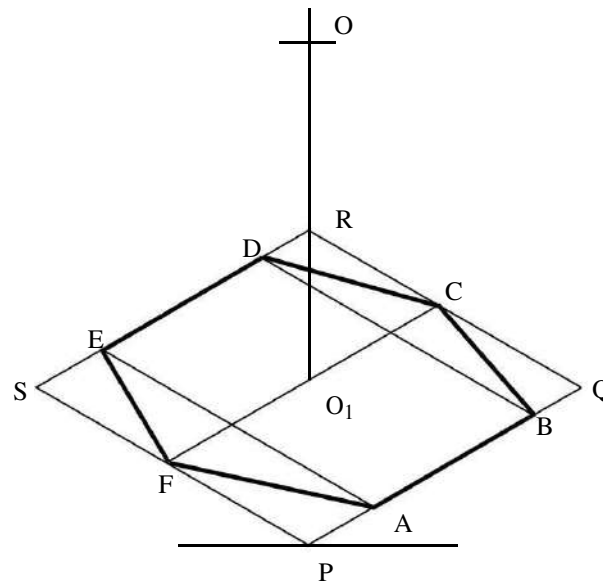
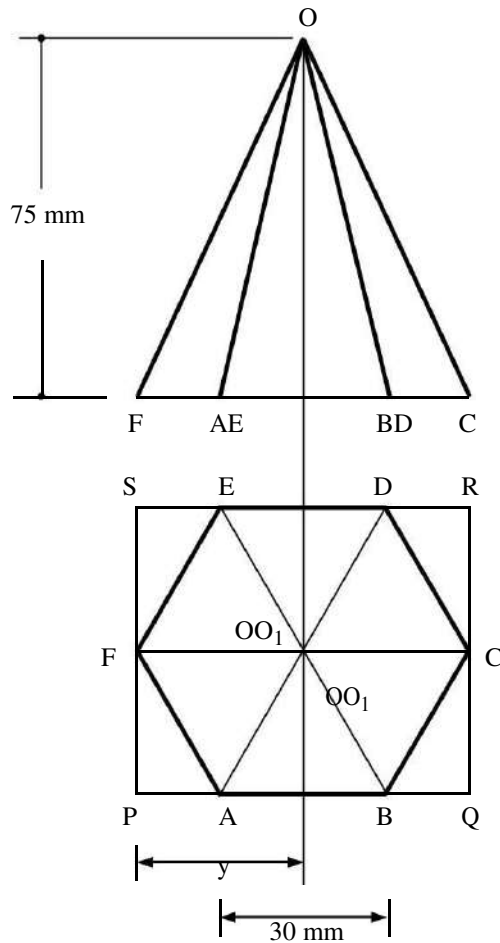

EXAMPLE – 2

Draw the isometric projection of a cone of base 40 mm diameter and height 58 mm when it rest with its base on H.P

Drawing Procedure

- Draw the orthographic projections of the cone.
- Enclose the circle in top view in a square $PQRS$.
- Draw the isometric vies of the base of the pyramid in the parallogram $PQRS$.
- Draw the base of the cone as an ellipse by Four-centre method.
- From B and C draw line parallel to isometric axes and obtain O_1 (Offset method).
- From O_1 draw a line parallel to the third axis. On this line mark O such that $O_1O =$ height of the cone = 58 mm
- From O draw two tangents to the ellipse and complete the isometric projection of the cone.

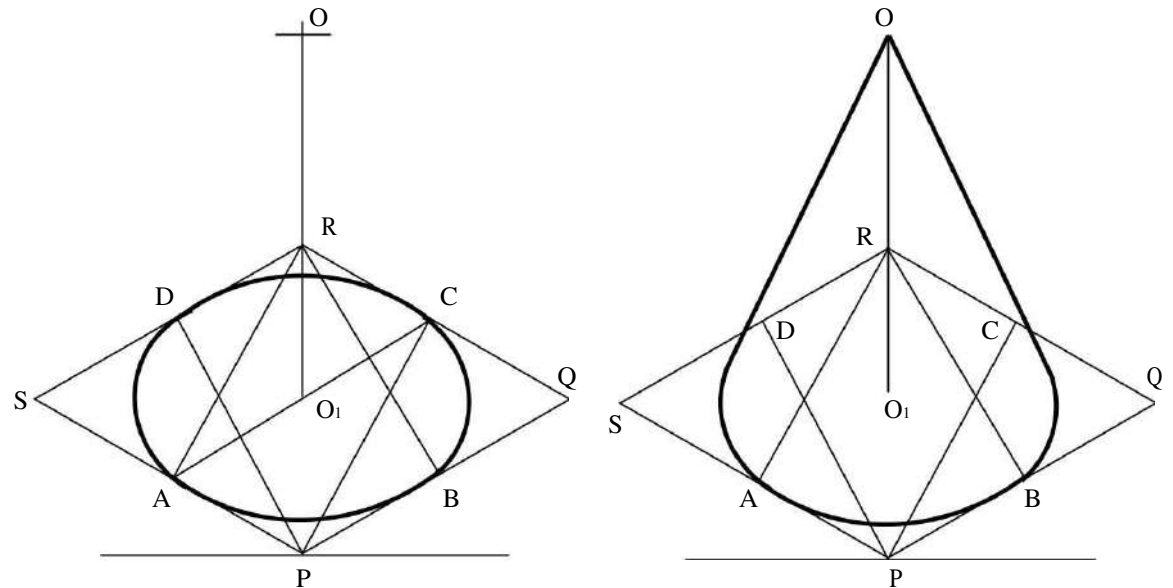
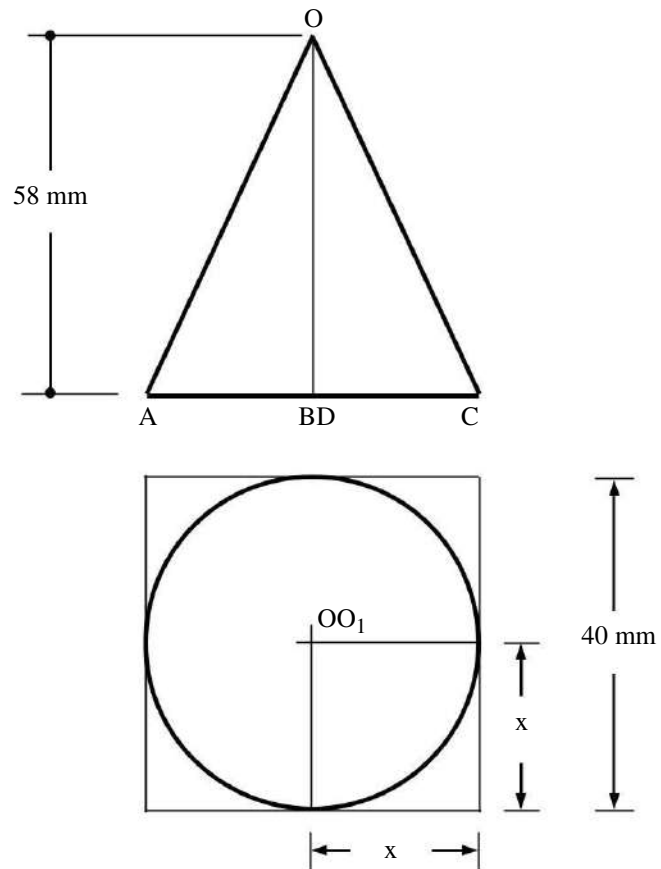

Draw the Top view, Front view, Right view, Left view and Back view for the following isometric view

1.

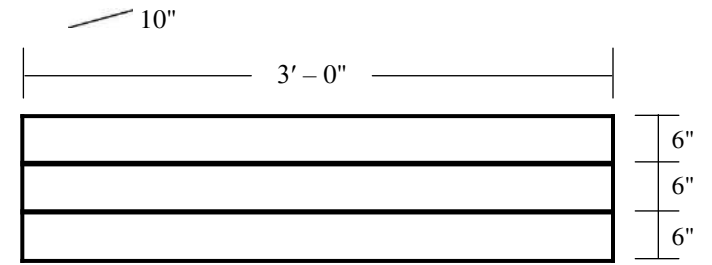
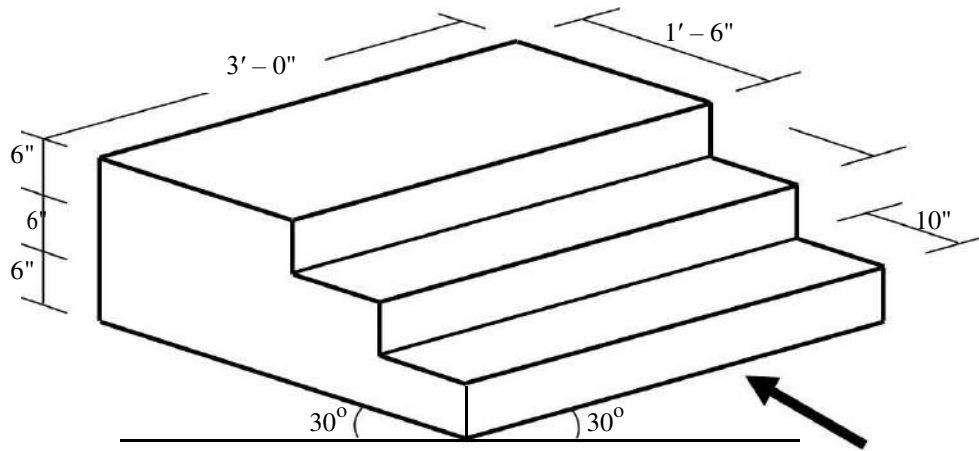

FRONT VIEW

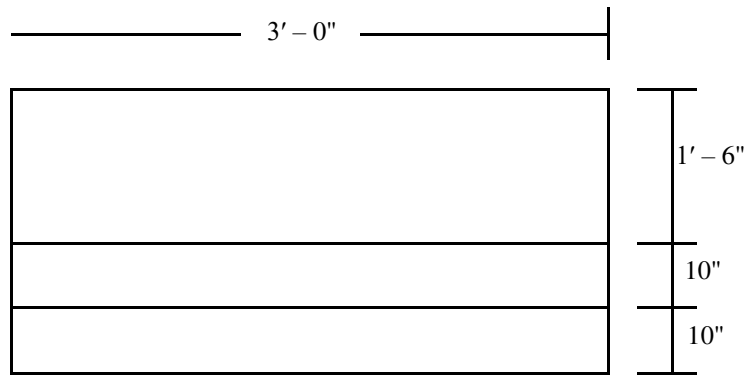

TOP VIEW

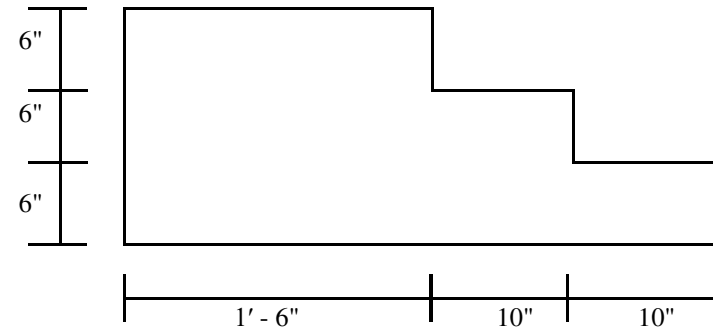

LEFT VIEW

2.

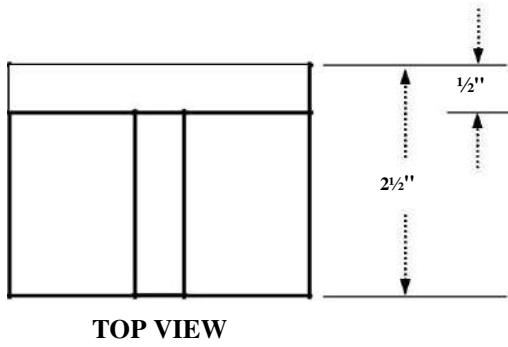
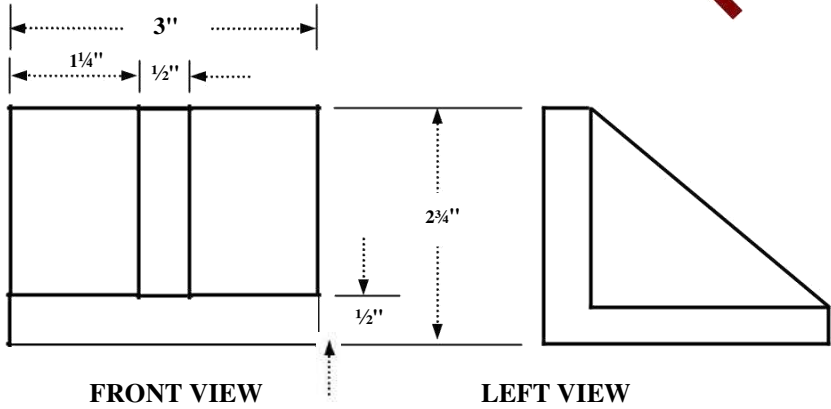
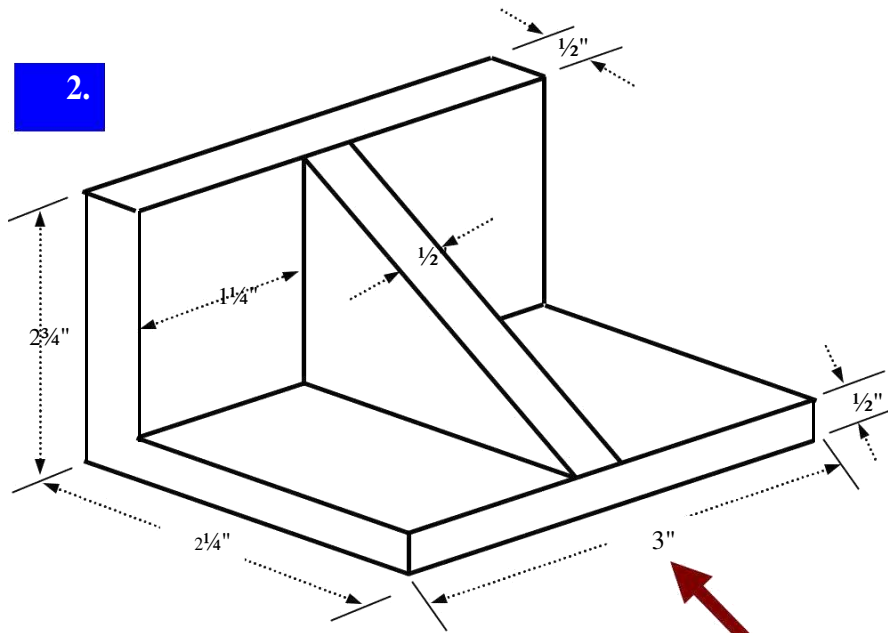

3.

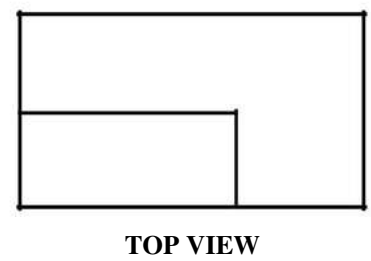
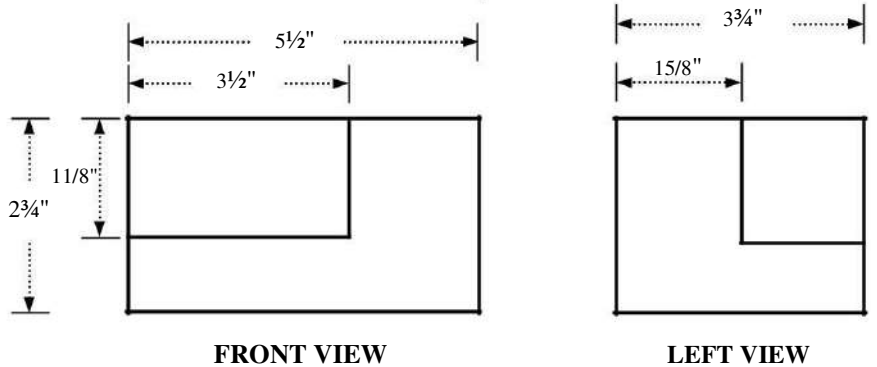
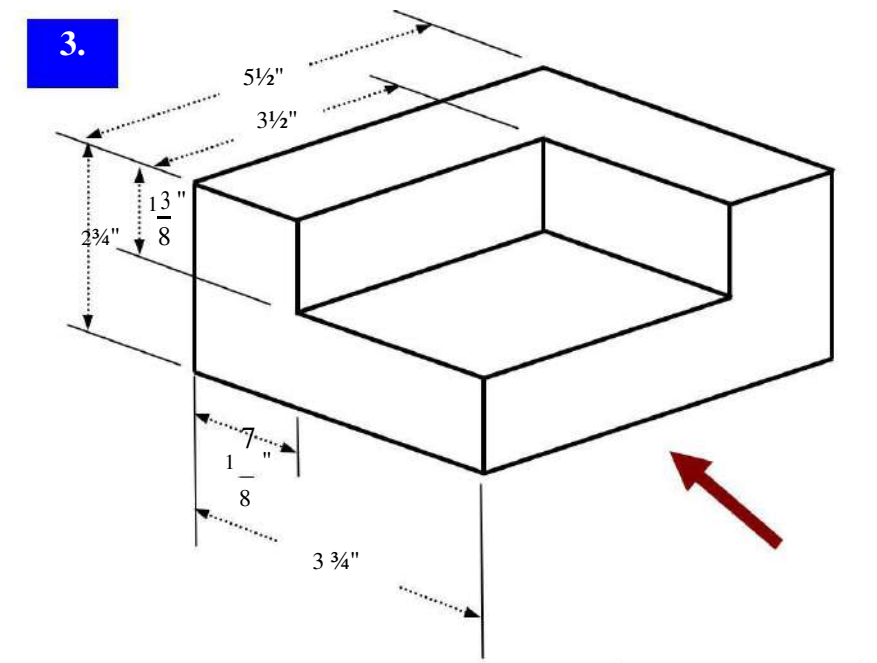

4.

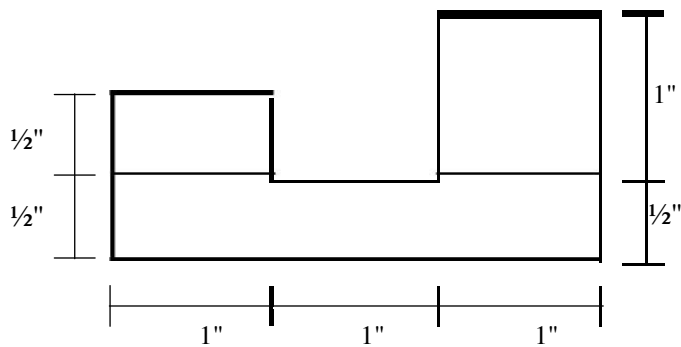
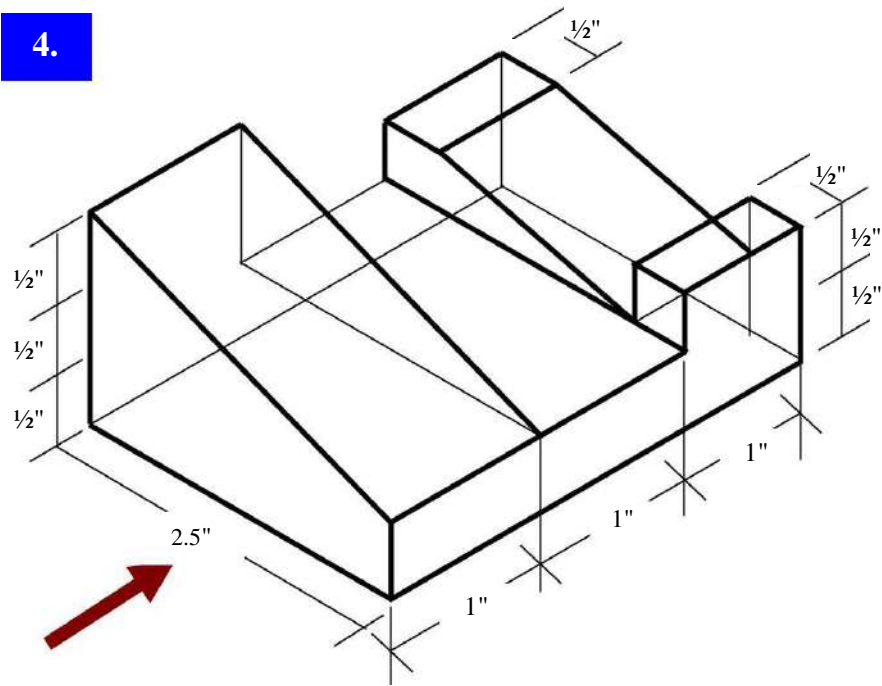

LEFT VIEW

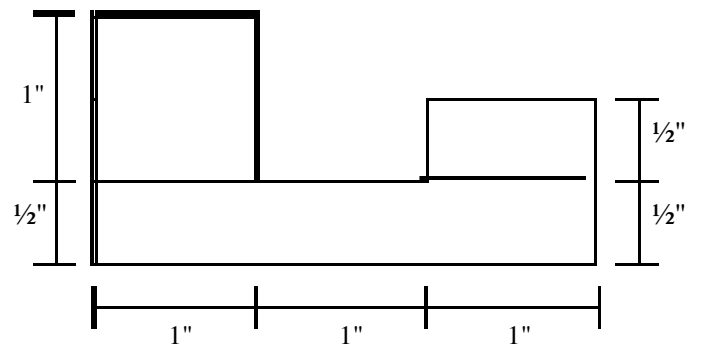

RIGHT VIEW

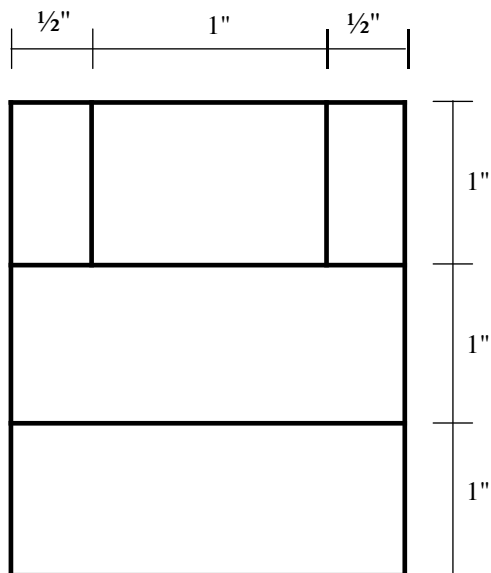

TOP VIEW

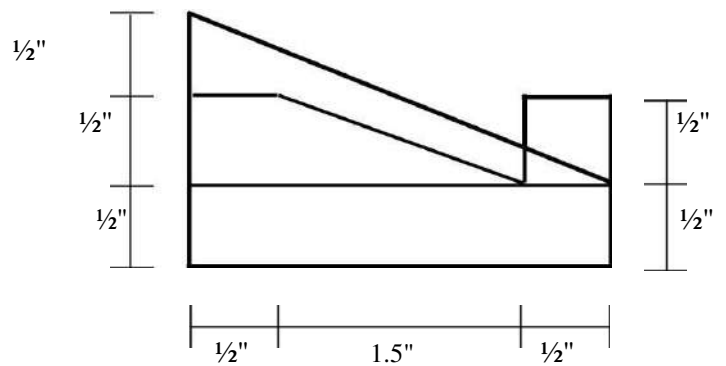

FRONT VIEW

5.

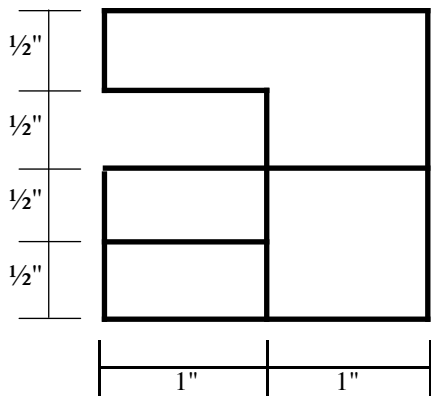
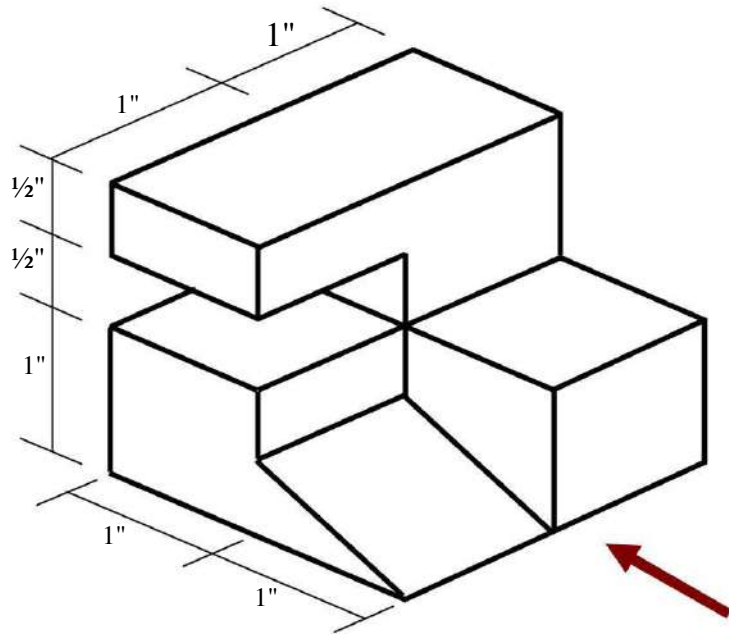

FRONT VIEW

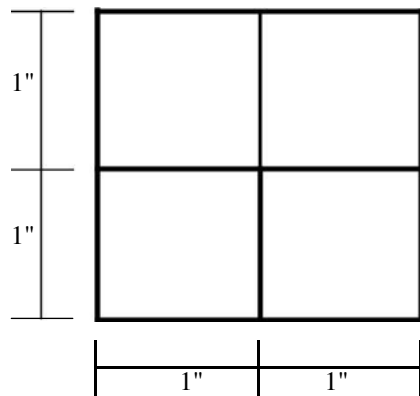

TOP VIEW

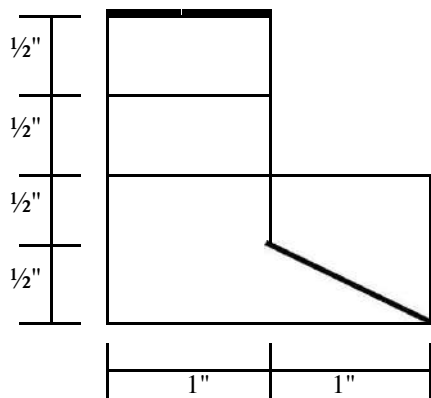

LEFT VIEW

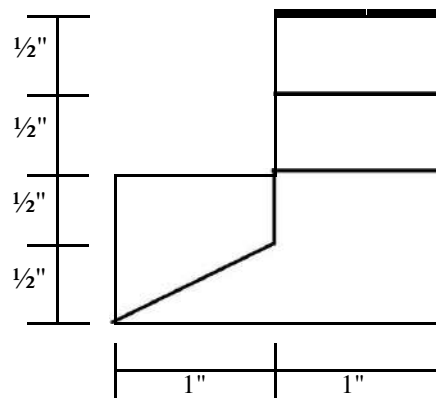

RIGHT VIEW

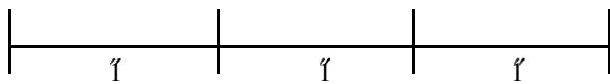
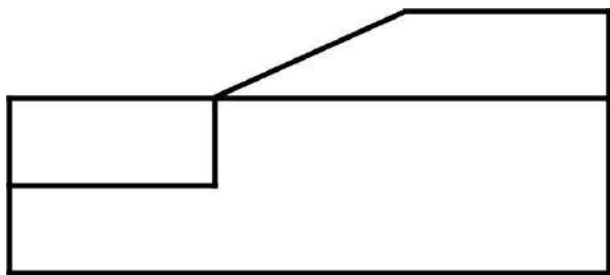
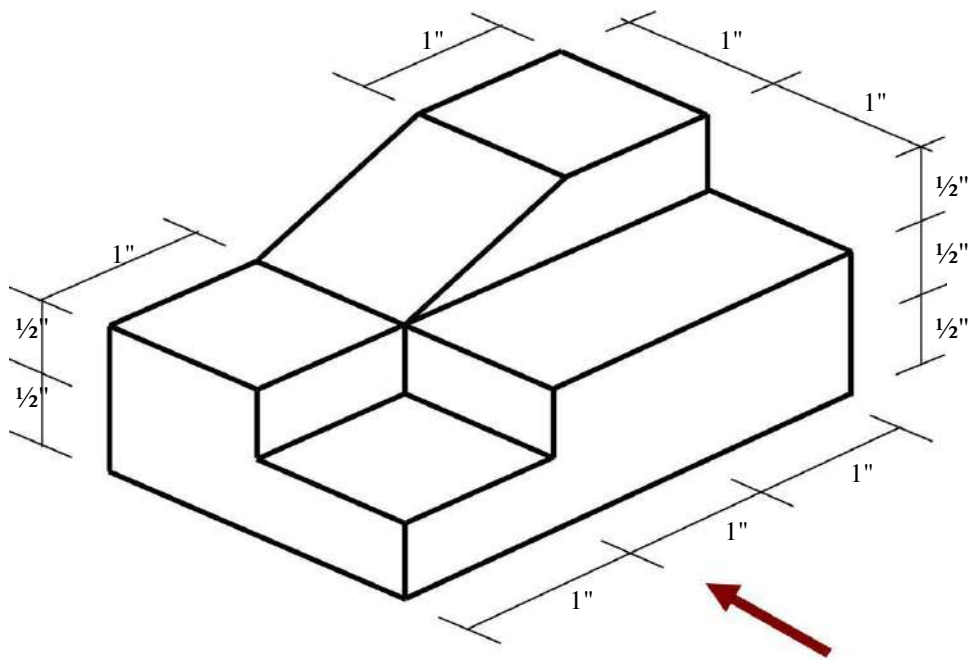

FRONT VIEW

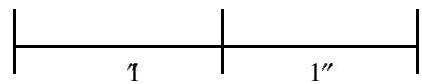
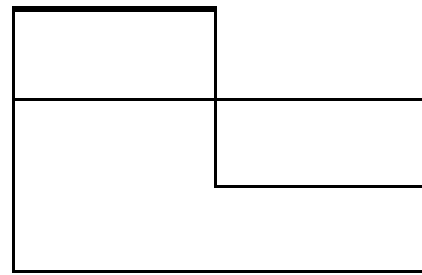
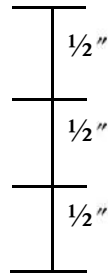

LEFT VIEW

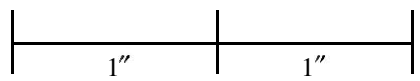
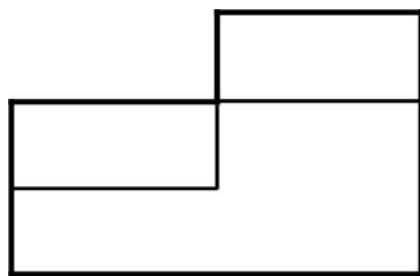
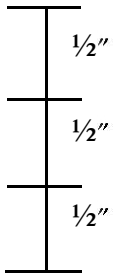

RIGHT VIEW

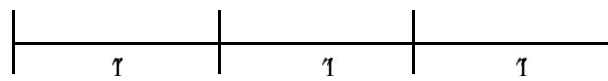
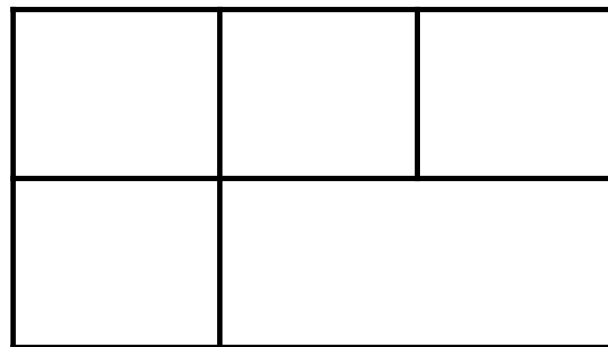
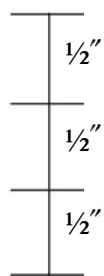

TOP VIEW

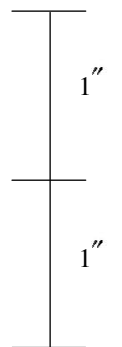

7.

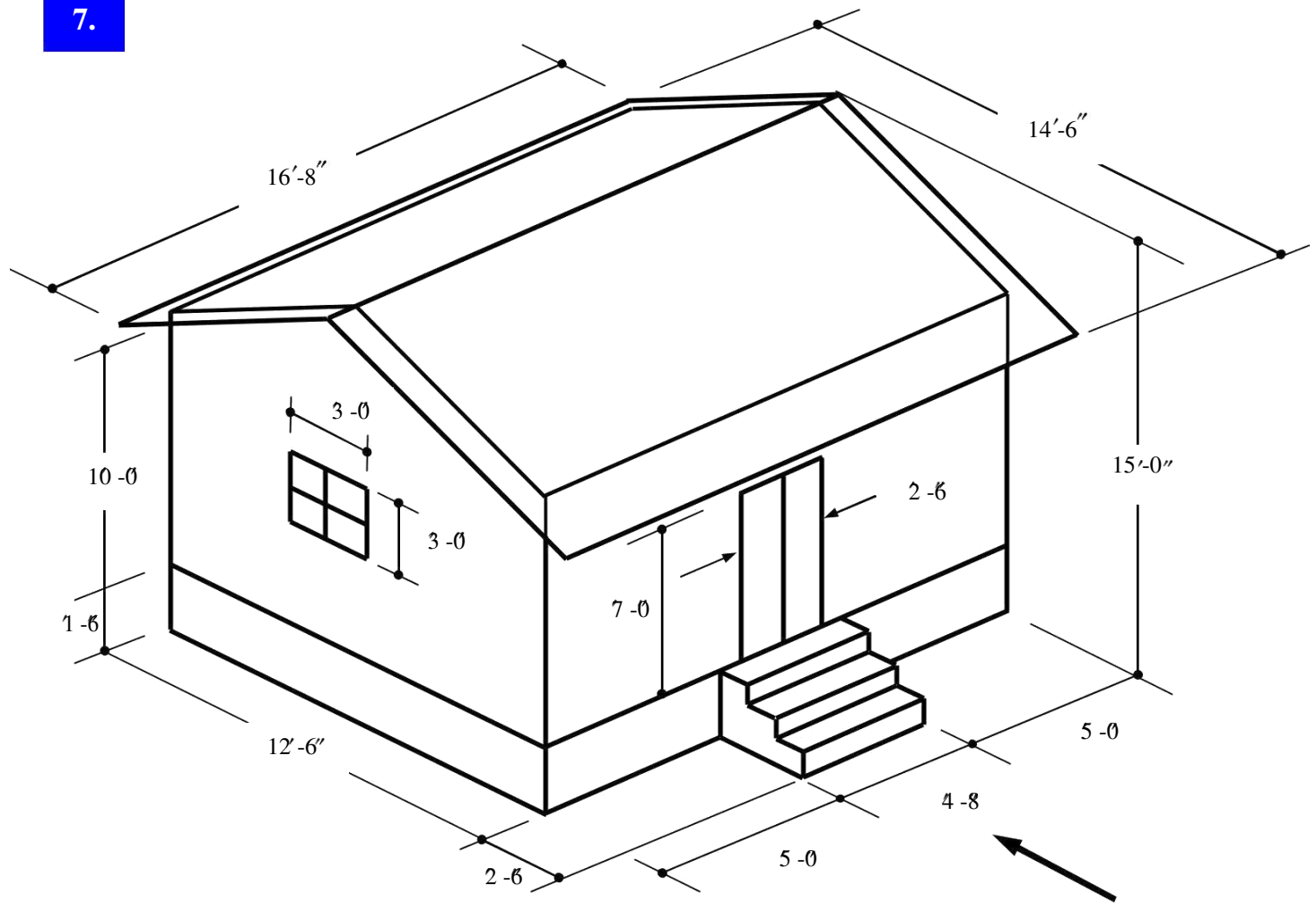

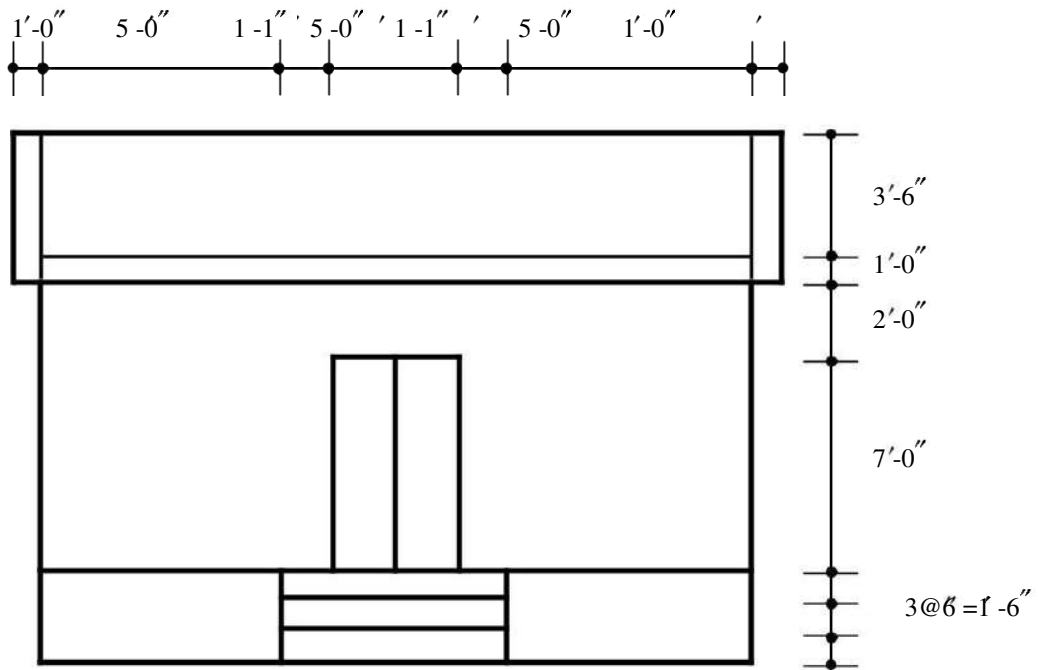

FRONT VIEW

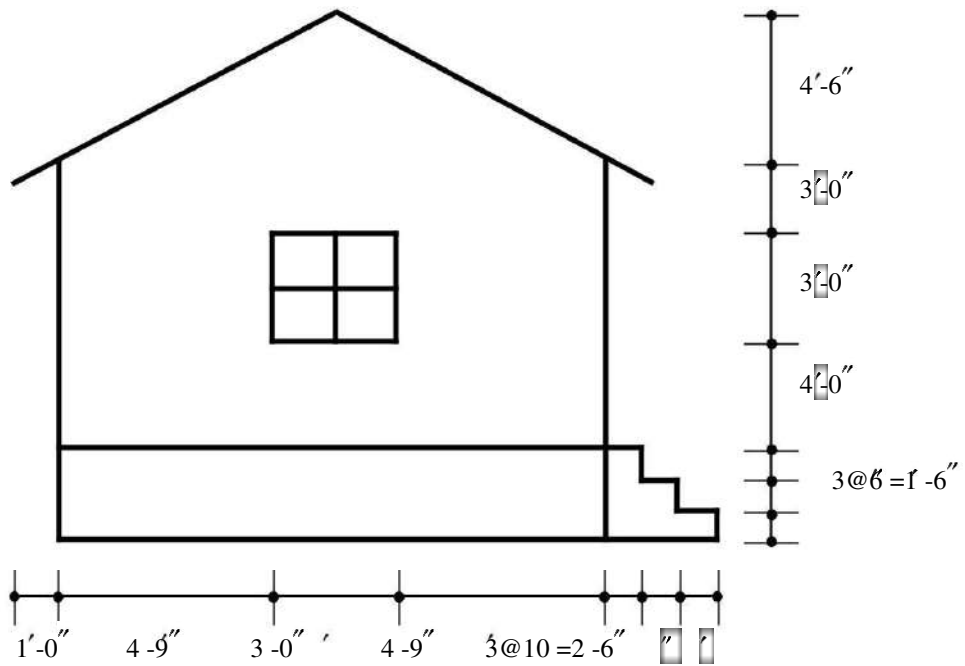

LEFT VIEW

